



TD10



PN16 - PN40

Pneumatic & Electric Diverting Valve European std.

The OMC **TD10** Series is a three-way globe-style control valve, for applications requiring diverting flow in a process control system. The open flow paths and simple construction provide a reliable and easy-to-maintain valve solution.

TD10 series could be manufactured with pneumatic or electric actuators to meet all application requirements. It is suitable for use for water, steam, thermal oil, gas and other liquids (where compatible material options are used).



14/68/EU (PED)
14/34/EU (ATEX)



EAC Conformity
CU TR 010 / CU TR 032



Safety Integrity Level
IEC EN 61508 - TÜV



Fugitive emissions
ISO 15848-1

- ◆ From DN15 to DN200 - PN16/40
- ◆ Top Guided construction to ensure plug stability
- ◆ Designed and engineered for robustness in demanding applications
- ◆ Modular design
- ◆ CEI EN 60534-6-1 Clamp and Yoke Std.
- ◆ Std. self adjusting double packing spring loaded
- ◆ Shutoff capabilities : Class IV (std.) , VI



OPTIONS

Reduced area trim to provide wide capabilities for all sizes

Hardened trims to handle high pressure drop applications

Low noise & anticavitation design cage

Bellows seal to meet zero emissions (ZEB20)

Bonnet for low temperature and for high temperature

Full St.Steel actuator construction

BW / SW / RTJ connections & special on request

Heating jacket



REFERENCE STANDARDS

Quality system management certification	ISO 9001
Design std.	EN12516-2
Flange connection (steel)	EN 1092-1
Flange connection (Spheroidal graphite)	EN 1092-2
Socket-Welding Ends	EN 12760
Buttwelding Ends	EN 12627
Pressure Rating	PN16 / PN40
Face to face dimension	EN 558-1
Seat tightness Class	IEC 60534-4
Positioner mounting	CEI EN 60534-6-1
2014/68/EU (PED) Certification	Modulo B + C2
Mechanical resistance calculation method	UNI EN 12516-2
Hydrostatic pressure test	EN 12266-1
Pressure / Temperature relationship (steel)	EN 1092-1
Pressure / Temperature relationship (Spheroidal graphite)	EN 1092-2
2014/34/EU (ATEX) Conformity	II 2 G Ex h IIC T6...T1 Gb II 2 D Ex h IIIC T6...T1 Db
Non-electrical equipment for explosive atmospheres Basic method and requirements	EN ISO 80079-36
Safety Integrity Level (SIL)	IEC EN 61508
Safety Integrity Level (SIL) Approval	SIL 3 - (C-IS-722133629)
Fugitive emissions Certification	ISO 15848-1
EAC Conformity	CU TR 010 / CU TR 032
NACE	MR0175



STD VALVE BODY CHARACTERISTICS

Style	Top entry, globe valve
Sizes	from DN15 to DN200
Pressure rating	PN16 / PN40
Design std.	EN12516-2
Flange connection	EN 1092-1- Raised Face - Phonography serrated 125-250 AARH
Face to face dimensions	EN 558-1

STD BODY & TRIM MATERIALS COMBINATION

VALVE BODY (1)	BONNET	TRIM	TIE ROAD	NUTS	BODY GASKET
Spheroidal graphite cast iron EN-GJS-400-18 RT (5.3104)	ASTM A105	ASTM A182 F316	A193 B7	A194 H2	Graphite + INOX
Carbon steel ASTM A216 WCC					
Stainless steel ASTM A351 CF8M	ASTM A182 F316	ASTM A182 F316	A193 B8M	A194 8M	Graphite + INOX

CONSTRUCTION EXAMPLES

1. Valve body
2. Upper plug
3. Upper seat ring
4. Lower seat ring
5. Lower plug
6. Top Guide sliding bush
7. Body gasket
8. Bonnet
9. Stem
10. Stuffing box

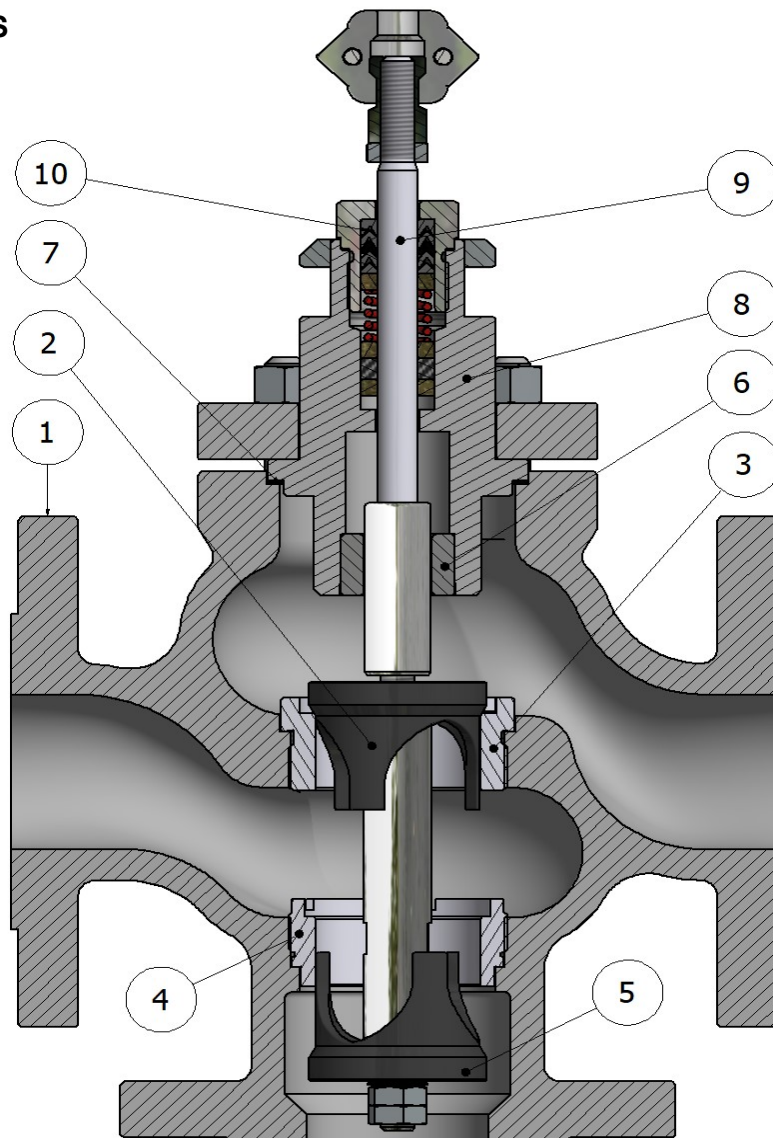

STANDARD VALVE



CONSTRUCTION EXAMPLES

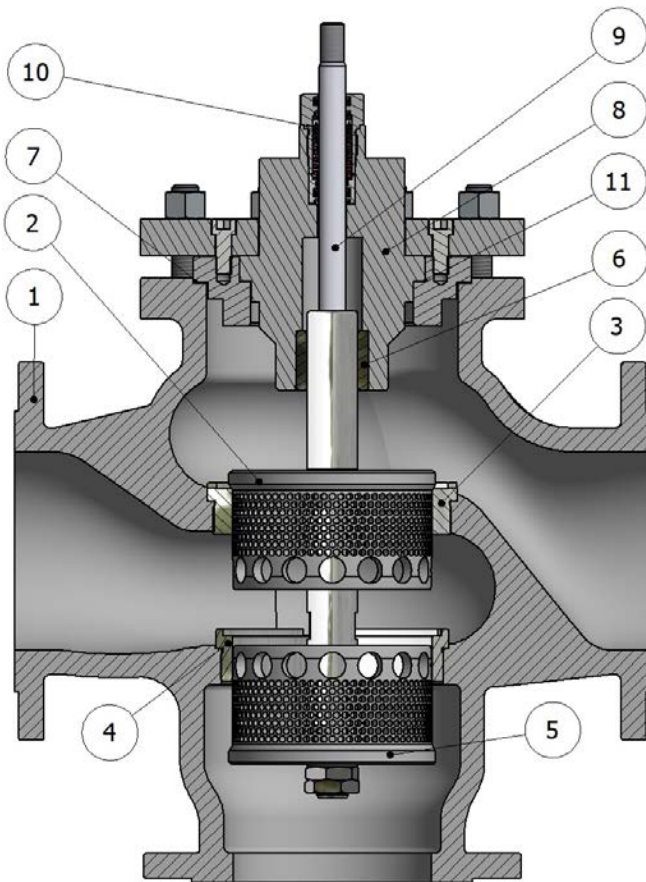

VALVE WITH CAGE PLUGS

1. Valve body
2. Cage upper plug
3. Upper seat ring
4. Lower seat ring
5. Cage lower plug
6. Top Guide sliding bush
7. Body gasket
8. Bonnet
9. Stem
10. Stuffing box
11. Bonnet gasket

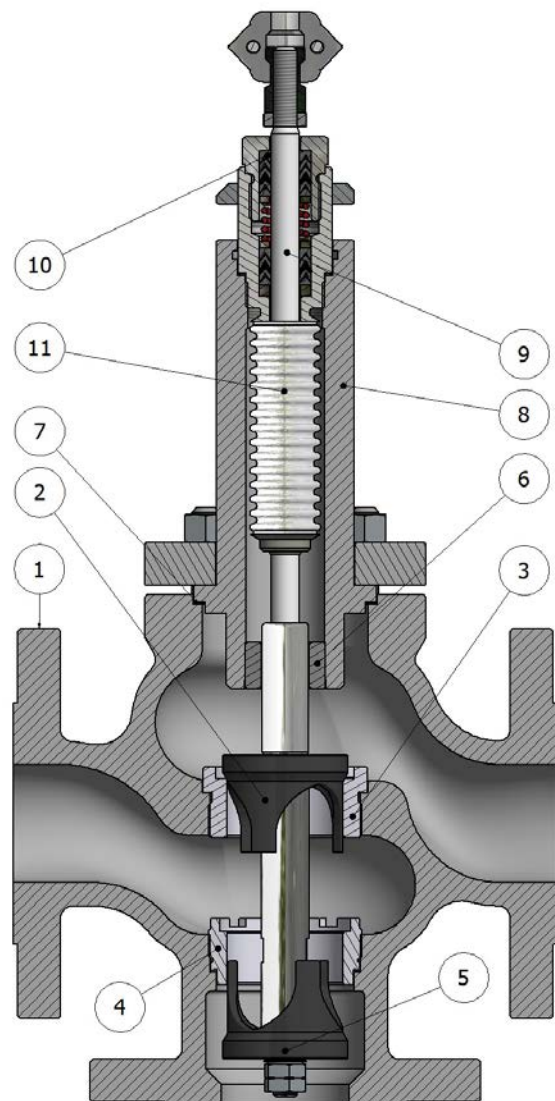

VALVE WITH BELLOWS

1. Valve body
2. Upper plug
3. Upper seat ring
4. Lower seat ring
5. Lower plug
6. Top Guide sliding bush
7. Body gasket
8. Bonnet
9. Stem
10. Stuffing box
11. Bellows



WORKING PRESSURE BY CLASS STD MATERIALS

OPERATING TEMPERATURE	EN-GJS-400-18 RT (5.3104) (-10° ÷ 350°C)	ASTM A105 / EN10273 1.0619 / EN10273 1.0345 (-29° ÷ 450°C)		ASTM A216 WCC (-29°÷450°C)		A351 CF8M / EN10273 1.04408 A182 F316 / EN10272 1.4529 (-253°÷600°C)	
	°C	PN16 (bar)	PN16 (bar)	PN40 (bar)	PN16 (bar)	PN40 (bar)	PN16 (bar)
RT	16.0	16.0	40.0	16.0	40.0	16.0	40.0
100	16.0	14.8	37.1	16.0	40.0	16.0	40.0
150	15.5	14.0	35.2	16.0	40.0	14.5	36.3
200	14.7	13.3	33.3	16.0	40.0	13.4	33.7
250	13.9	12.1	30.4	15.6	39.0	12.7	31.8
300	12.8	11.0	27.6	14.0	35.2	11.8	29.7
350	11.2	10.2	25.7	12.9	32.3	11.4	28.5
400	—	9.5	23.8	11.8	29.5	10.9	27.4
450	—	5.2	13.1	6.4	16.1	10.7	26.9
500	—	—	—	—	—	10.5	26.4
550	—	—	—	—	—	10.4	26.0
560	—	—	—	—	—	10.3	25.7
570	—	—	—	—	—	10.1	25.4
580	—	—	—	—	—	10.0	25.0
590	—	—	—	—	—	9.9	24.7
600	—	—	—	—	—	8.9	22.7

MATERIALS AVAILABLE ON REQUEST

Carbon steel	A352 LC2; A352 LC3; A352 LCC; A352 LCB
Alloy Carbon Steel	A217 WC6; A217 WC9
Austenitic Stainless Steel	A351 CF3; A351 CF8; A351 CF10; A351 CF3M; A351 CF8M; A351 CF10M
Ferritic Austenitic Stainless Steel (DUPLEX / SUPERDUPLEX)	A995 CD3MWCuN; A995 A6; A351 CK3MCuN; A351 CE8MC; A351 CD3MN; A351 CD4MCuN
Nickel Alloy Stainless Steel	A494 M35-1 (MONEL); A494 M35-2 (MONEL); A494 N-12MV (HASTELLOY B); A494 CW-12MW (HASTELLOY C)
TIES ROAD & NUTS	In according to the body material



STANDARD PROTECTIVE COATING

WORKING TEMPERATURE	VALVE BODY	BONNET
from -29° to 150°C	<ul style="list-style-type: none"> • Bicomponent anticorrosive acrylic primer at high resistance • Finish with bicomponent aliphatic acrylic enamel RAL 7021 opaque 	Electrolytic zinc coatings Fe/Zn 8 c1A UNI ISO 4520
from 150° to 250°C	<ul style="list-style-type: none"> • Siliconic primer • Finish with siliconic enamel RAL 9005 	Electrolytic zinc coatings Fe/Zn 8 c1A UNI ISO 4520
from 250° to 400°C	<ul style="list-style-type: none"> • Heat resistant siliconic primer • Finish with siliconic enamel RAL 9006 	

PNEUMATIC ACTUATOR STANDARD PROTECTIVE COATING

CASING AND YOKE

Polyester electrostatic epoxy powder coating - RAL 7032

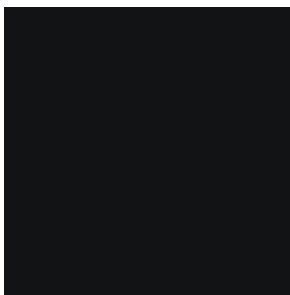

RAL 7021

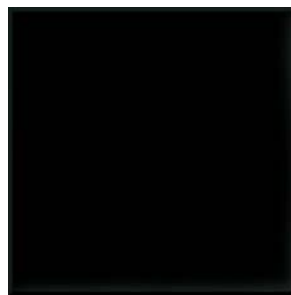

RAL 9005

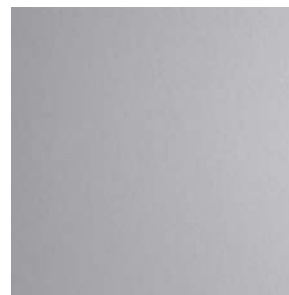

RAL 9006



RAL 7032

Colors and shades shown in the figure are indicative

PROTECTIVE COATING ON REQUEST

Customer specification colors

Painting for sea environment

Painting in according to ISO 12944



Painting in according to NORSOK M-501

NACE - FROSIO painting



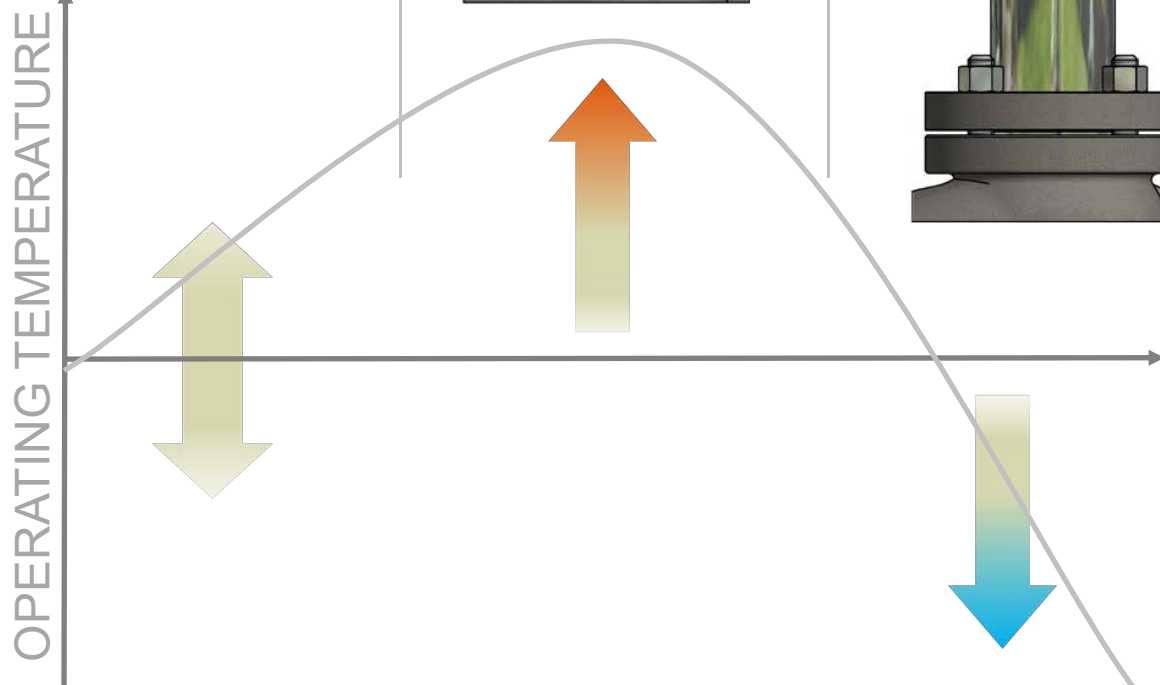

BONNET TYPES

STANDARD	FINNED	EXTENDED
<p>The standard bonnet is cast or forged from the same or equivalent grade of material as the valve body. It is suitable for applications with temperatures between</p> <p style="text-align: center;">-5°C to +220°C</p>	<p>The finned bonnet is cast or forged from the same or equivalent grade of material as the valve body.</p> <p>Engineered for high temperature applications the fins dissipate heat and protect valve stem packing from extreme process temperatures up to +200°C</p> <p style="text-align: center;">-5°C ÷ 600°C</p>	<p>The extended bonnet is cast or forged from the same or equivalent grade of material as the valve body.</p> <p>To protect the stem packing the extended bonnet traps some process fluid. This provides a thermal buffer between the packing and the low temperature process fluid.</p> <p>Engineered for low temperatures, the extension length is manufactured to suit the applications where minimum temperature medium is below -5°C.</p> <p style="text-align: center;">-196°C ÷ 220°C</p>
		
 <p style="writing-mode: vertical-rl; transform: rotate(180deg);">OPERATING TEMPERATURE</p>		



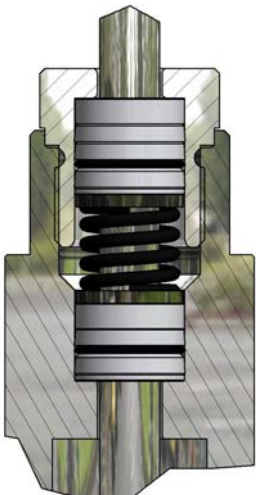
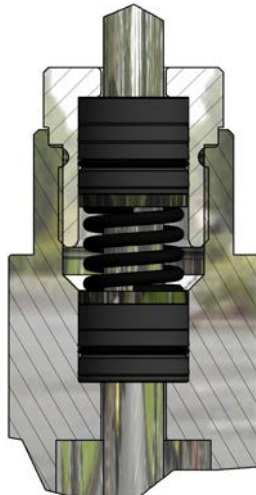
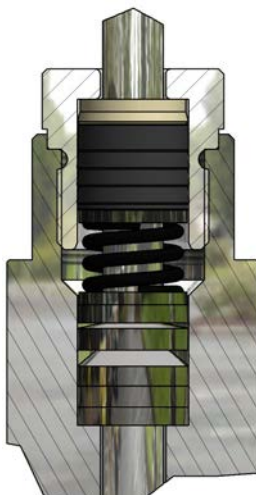
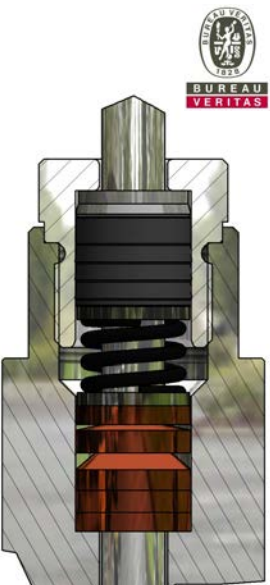

PACKING TYPES - VALVES FROM DN15 UP TO DN100

LP200	SP200	HP300	ECOPACK 1
<p>It consists of a series of energized V ring pack in Virgin PTFE and FKM, especially used with Oxygen and Cryogenic applications.</p> <p>Self-adjusting and maintenance free.</p>	<p>It consists of a series of energized V ring pack in PTFE base & FKM 75 Shore. Suitable for low & medium temperature application.</p> <p>Self-adjusting and maintenance free.</p>	<p>Directly in contact with the medium it consists of a series of energized V ring pack in Graphite and PTFE. Especially used for high temperature applications.</p> <p>Self-adjusting and maintenance free.</p>	<p>Made of a series of energized V ring pack in Graphite/PTFE. ISO 15848-1 Certified for Low emission fugitive test.</p> <p>Self-adjusting and maintenance free.</p>
			

PACKING / BONNET TEMPERATURE CORRELATION

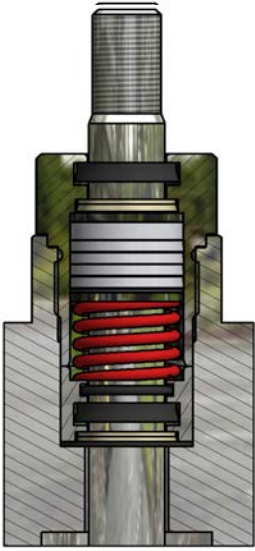
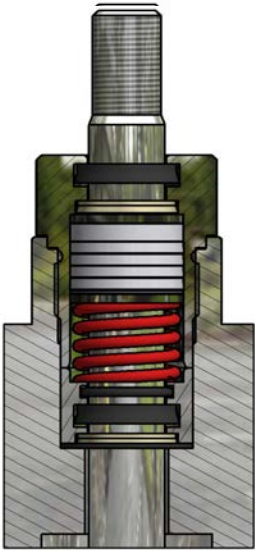
	LP200	SP200	HP300	ECOPACK 1
CRYOGENIC BONNET	-196 ÷ 180°C	///	///	--196 ÷ 180°C
EXTENDED BONNET	-90 ÷ 180°C	-90 ÷ 220°C	///	-90 ÷ 220°C
STANDARD BONNET	-5 ÷ 180°C	-5 ÷ 220°C	///	-5 ÷ 220°C
FINNED BONNET	///	-5 ÷ 260°C	-5 ÷ 400°C	-5 ÷ 400°C
EXTENDED FINNED BONNET	///	///	-5 ÷ 600°C	///
EXTENDED BONNET FOR BELLOWS	///	-90 ÷ 260°C	-5 ÷ 400°C	-90 ÷ 400°C
EXTRA EXTENDED BONNET FOR BELLOWS	-196 ÷ 180°C	///	-5 ÷ 600°C	///

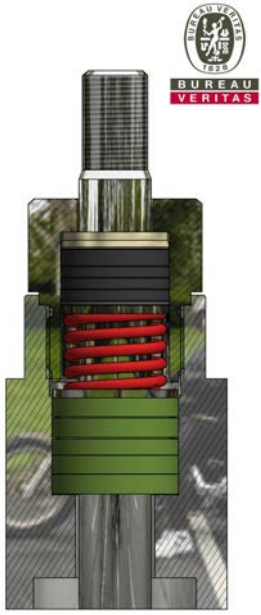
PACKING TYPES - VALVES FROM DN125 UP TO DN200

LP400	SP400	HP600	ECOPACK 2
<p>It consists of a series of energized V ring pack in Virgin PTFE and FKM, especially used with Oxygen and Cryogenic applications.</p> <p>Self-adjusting and maintenance free.</p>	<p>It consists of a series of energized V ring pack in PTFE base & FKM 75 Shore. Suitable for low & medium temperature application.</p> <p>Self-adjusting and maintenance free.</p>	<p>Directly in contact with the medium it consists of a series of energized V ring pack in Graphite and PTFE. Especially used for high temperature applications.</p> <p>Self-adjusting and maintenance free.</p>	<p>Made of a series of energized V ring pack in Graphite/PTFE. ISO 15848-1 Certified for Low emission fugitive test.</p> <p>Self-adjusting and maintenance free.</p>
			

PACKING / BONNET TEMPERATURE CORRELATION

	LP400	SP400	HP600	ECOPACK 2
CRYOGENIC BONNET	-196÷ 180°C	///	///	--196 ÷ 180°C
EXTENDED BONNET	-90 ÷ 180°C	-90 ÷ 220°C	///	-90 ÷ 220°C
STANDARD BONNET	-5 ÷ 180°C	-5 ÷ 220°C	///	-5 ÷ 220°C
FINNED BONNET	///	-5÷260°C	-5 ÷ 400°C	-5 ÷ 400°C
EXTENDED FINNED BONNET	///	///	-5 ÷ 600°C	///
EXTENDED BONNET FOR BELLOWS	///	-90÷260°C	-5 ÷ 400°C	-90 ÷ 400°C
EXTRA EXTENDED BONNET FOR BELLOWS	-196÷ 180°C	///	-5 ÷ 600°C	///



ZEB20 BELLOWS FOR DANGEROUS FLUID

ZEB20 is specifically designed for industrial applications where the possible leakage of process fluid from the packing can cause environmental or personal damage and in extreme cases be hazardous to health.

The ZEB20 is manufactured by welding a bellows to the plug stem and valve bonnet. This removes potential leakage paths, while allowing full movement of the stem. The design provides total isolation of the fluid from the outside environment.

The ZEB20 also includes secondary stem seals as a safety function. These only operate in the unlikely event that a bellows ruptures. The secondary seals will provide reduced risk.

The standard of the bellows material is AISI 316L but, it is also available in in other materials, including Inconel, Monel, Hastelloy, etc...

For safety critical applications the ZEB20 can be fitted with a test connection to allow the addition of feedback devices that monitor the integrity of the bellows

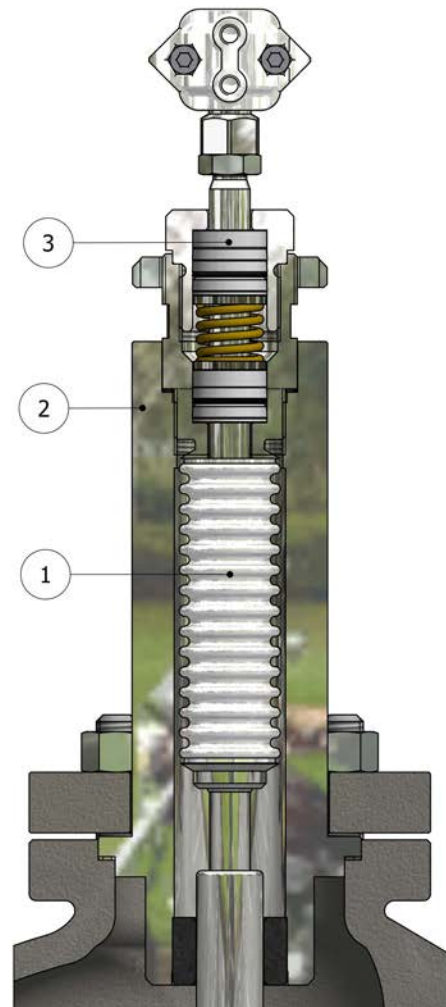

Fugitive emissions
ISO 15848-1

ZEB20 MATERIALS COMBINATION

POS.	DESCRIPTION	STD MATERIALS	ON REQUEST	TEMPERATURE
1	Bellows	AISI 316L	Inconel, Monel, Hastelloy, or other materials	-196°C ÷ 600°C
2	Bonnet	Equal or equivalent to the material of the body valve	Other materials	-196°C ÷ 600°C
3	Packing	See packing type chapter		

TRIMS CHARACTERISTICS

	STANDARD	ON REQUEST
CONTROL CHARACTERISTICS	Linear (PL)	
PORT	Full port	Reduced port
SEAL	Metal seat tightness Class IV	Saline nitriding (QPQ) seat/plug Class IV



Standard Trim

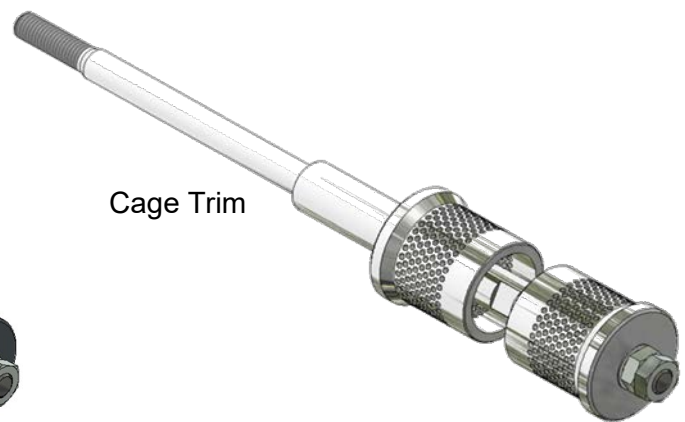

Cage Trim

FLOW RATE COEFFICIENTS SEAT BORE DIAMETER AND PLUG STROKE

CV	Kv	Seat bore diameter mm	Std plug stroke mm	Valve size (DN)												
				15	20	25	32	40	50	65	80	100	125	150	200	
4.5	3.8	15	20	■	□	□	□	□	□	—	—	—	—	—	—	
6	5.1	20		—	■	□	□	□	□	—	—	—	—	—	—	
11	9.4	25		—	—	■	□	□	□	□	□	—	—	—	—	
18	15.4	30		—	—	—	■	□	□	□	□	□	—	—	—	
27	22.2	38		—	—	—	—	■	□	□	□	□	—	—	—	
47	40.1	49		—	—	—	—	—	■	□	□	□	—	—	—	
73	63.4	64	30	—	—	—	—	—	—	■	□	□	□	□	—	
105	89.7	76		—	—	—	—	—	—	—	—	■	□	□	□	
160	136.7	96		—	—	—	—	—	—	—	—	—	■	□	□	
270	230.8	126	50	—	—	—	—	—	—	—	—	—	—	■	□	
370	316.2	151		—	—	—	—	—	—	—	—	—	—	—	■	□
650	555	201		—	—	—	—	—	—	—	—	—	—	—	—	■

— not available

■ standard

□ on request



AP SERIES PNEUMATIC ACTUATORS - SPECIFICATIONS

AP series pneumatic actuators are multi diaphragm actuators. They are Available with four (4) different sizes of internal diaphragms. They are extremely compact and they can guarantee a perfect linearity to satisfy the control needs of the valves at different working pressures. They are equipped with an industry standard yoke (CEI EN 60534-6-1), which ensures accessories can be fitted quickly and easily. A full range E/P positioners, solenoid valves, limit switch boxes and feedback devices are available as option. As you standard a mechanical travel indicator and index scale are included as standard on all actuators.

TECHNICAL DATA

TYPE	Diaphragm type - multispring	
CONTROL SIGNAL	Direct Action (Air to close - valve normally open) 6÷18psi; 6÷30psi; 15÷60psi Reverse (Air to open - valve normally closed) 6÷18psi; 6÷30psi; 15÷60psi	3÷15psi ; 3÷15psi ;
MAX AIR SUPPLY PRESSURE	50 psi (3,5bar) for signals 3÷15psi ; 6÷18psi; 6÷30psi; 87 psi (6 bar) for signal 15÷60 psi	
PNEUMETIC CONNECTION	1/4" NPF-F	

MATERIALI

	STANDARD	ON REQUEST
YOKE	ASTM A216 WCB (T.amb \geq -29°C)	Stainless steel ASTM A351 CF8 (T.amb \geq -268°C)
HOUSING	Steel 1.0332 / 1.0335 (T.amb \geq -50°C)	Stainless steel AISI 304 (T.amb \geq -268°C)
	ASTM A216 WCB (*) (T.amb \geq -29°C)	Stainless steel ASTM A351 CF8 (*) (T.amb \geq -268°C)
BOLTS AND NUTS	A193 B7 - A194 2H (T.amb \geq -30°C)	A193 8M - A194 8M (T.amb \geq -268°C)
DIAPHRAGM	NBR (T.amb -35÷90°C)	EPDM (T.amb -50÷120°C) PVMQ (T.amb -60÷90°C)
SPLINDE	ASTM 182 F304	//
VALVE CLAMP CONNECTION	ASTM A 351 CF8	//
SPRING	EN 10270-1 SH painted (T.amb \geq -30°C)	EN 10270-3 1.4310 (AISI 301) EN 10270-3 1.4401 (AISI 316) (T.amb \geq -268°C)
INTERNAL PARTS	Zinc plated Steel 1.0332 / 1.0335 (T.amb \geq -50°C)	Stainless steel AISI 304

(*) Actuators Series AP6.. only

1. Casing
2. Spring
3. Diaphragm
4. Splinde
5. Integral yoke
6. Valve clamp connection
7. Stroke indicator
8. Diaphragm plate

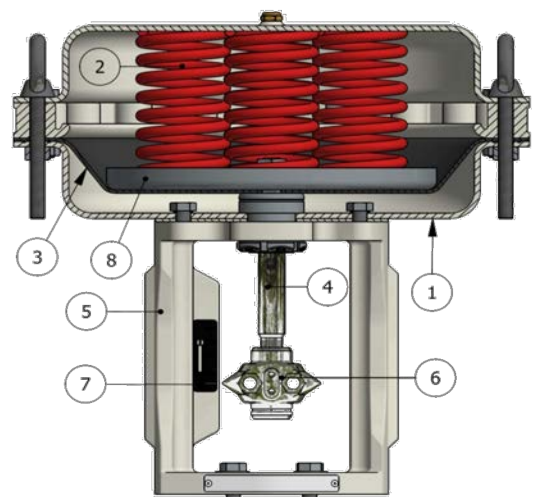

DIMENSIONS

DN	A mm	B mm	C mm			
			Std. bonnet	Bonnet with bellows	Finned / Extended bonnet	G mm
DN15	130	70	132	232	169	100
DN20	150	80	133	232	177	100
DN25	160	85	138	237	182	100
DN32	180	100	133	231	190	100
DN40	200	105	138	236	195	100
DN50	230	120	147	245	204	100
DN65 (*)	290	130	177	304	267	100
DN80	310	140	191	310	264	100
DN100	350	150	182	305	308	100
DN125	400	235	286	399	399	120
DN150	480	250	297	410	410	120
DN200	600	275	298	410	410	120

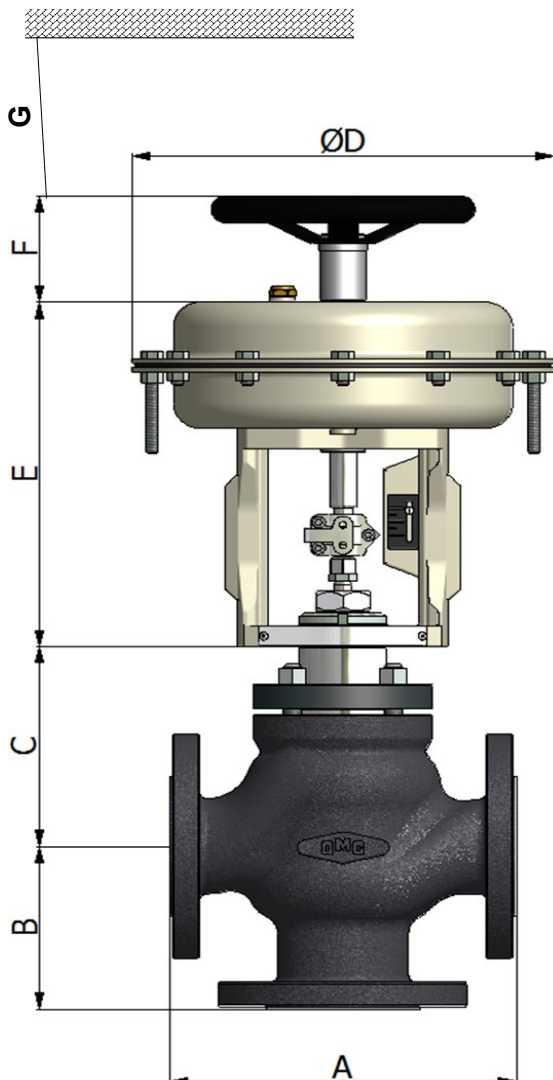

(*) According to standard EN1092-1 DN65 valves in carbon steel and stainless steel flanged PN16 must be provided with 8 holes. They can be supplied with 4 holes only at the specific request of the customer.

According to standard EN1092-2 DN65 valves in ductile iron flanged PN16 must be provided with 4 holes. They can be supplied with 8 holes only at the specific request of the customer.

According to standards EN1092-1 and 2, the valves DN65 PN16 must be provided with 8 holes

ACTUATOR

TYPE	Ø D mm	E mm	F mm		THRUST AREA cm ²	THRUST VOLUME liter
			(DIR.)	(REV.)		
AP23	230	245	135	85	203	~ 1.8
AP28	275	253			304	~ 3
AP34	342	276	185	85	475	~ 5.7
AP35		303	300	150	744	~ 11.5
AP43	430	393				
AP44		425	600	450	1690	~ 32
AP45	425	600				
AP46	600	450	//	//	1690	~ 32



PNEUMATIC PISTON SERIES OP

The OP series pneumatic actuators are used especially for multi-spring piston valves with ON-OFF function. Available in 2 sizes, are extremely compact. Equipped with mechanical stroke indicator, the integral yoke meets Std CEI EN60534-6-1 to direct mounting accessories such as, switches, etc ...

TECHNICAL DATA

TYPE	Piston type - multispring
CONTROL SIGNAL	from 90 psi (6 bar) to 145 psi (10 bar)
MAX AIR SUPPLY PRESSURE	145 psi (10 bar) (direct or reverse action)
PNEUMETIC CONNECTION	1/4" NPF-F
AMBIENT TEMPERATURE	-20+70°C

MATERIALS

	STANDARD	ON REQUEST
CASING	Painted Aluminium	//
YOKE	Painted Carbon steel	Electropolished Stainless Steel
BOLTS AND NUTS	A193 B7 - A194 2H	Other materials
PISTON	NBR	//
SPLINDE	ASTM 182 F304	//
VALVE CLAMP CONNECTION	ASTM A 351 CF8	//
SPRING	EN 10270-1SH painted	Stainless steel
INTERNAL PARTS	Zinc plated carbon steel	Stainless steel

PROTECTIVE COATING

STANDARD	Finish powder coat polyester RAL 7032
ON REQUEST	Painting for see environment Customer specification

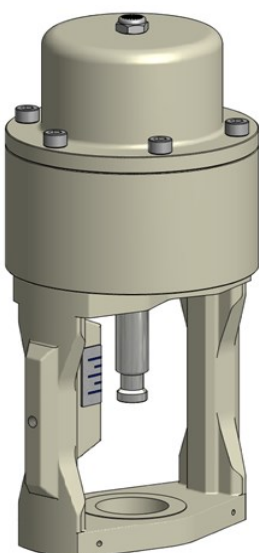

ACCESSORIES

- ◆ Alarm contacts
- ◆ Air filter regulator
- ◆ Solenoid valves

MAXIMUM ADMISSIBLE PRESSURE DROPS IN bar

ACTUA-TOR	CV 4,5	CV 6	CV 11	CV 18	CV 27	CV 47	CV 73	CV 105	CV 160
OP10	12	12	12	12	12	12			
OP16							12	8	3



The contents of this publication are presented for information purpose only. We reserve to modify or improve the designs or specifications of such products at any time without notice